

Sample specifications for WF-225

Cold water centrifugal atomizing type humidifier and mounting brackets for installation in return duct applications. Water reservoir includes float valve to automatically regulate water level. Humidifier includes motor, impeller, disk and breaker comb to produce a fine vapor. Rotating parts shall be electronically balanced to eliminate vibration. Tubes shall be employed to direct moisture into vertical or horizontal duct systems and equalize humidifier internal air pressure to that of the duct. All water exposed parts to be copper, brass, or non-ferrous alloy. Vapor output of the humidifier shall be constant while in operation and shall not depend on the temperature of the air or water. Humidifier(s) shall be Model WF-225 as manufactured by Humidity Source. Must be UL listed for US and Canada.

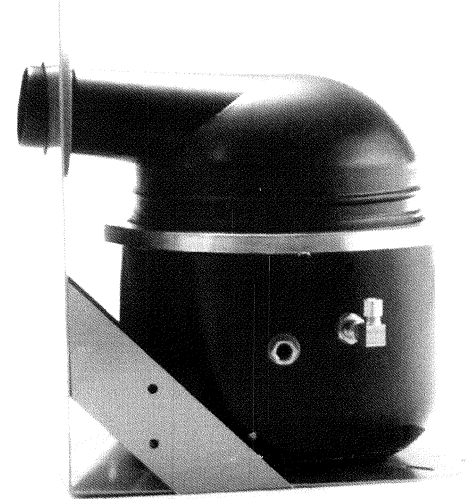

SPECIFICATIONS

CAPACITY

Moisture Output – 3.5 lb./hr.

WEIGHT

Net: 16 lb.
Shipping: 18 lb.
Operating: 20 lb.

WATER CONNECTIONS & PRESSURES

Supply: 1/8" Male Pipe Thread
Overflow: 1/4" Female Pipe Thread
Operating Pressure Range: 10-100 psig

Electric Motor

50 Watts
115 volts, single phase, 60 Hz.

CARTON SIZE

15 1/2" X 12 1/2" X 15 1/4"

UNIT SIZE

Height: 11 1/2"
Diameter: 10 1/4"

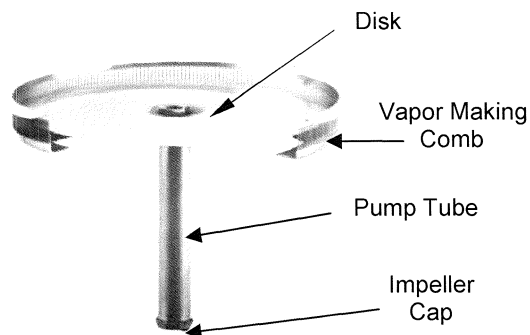

CENTRIFUGAL ATOMIZER

The heart of Humidity Source humidifier units is the patented masterfully engineered Centrifugal Atomizer. Water is drawn by centrifugal force up through the rotating impeller cap and pump tube, then spun across the disk rotating at 3250 RPM striking the Vapor-Maker Comb creating an extremely fine vapor. An integral fan under the rotating disk blows the vapor out of the unit resulting in a fine atomized vapor that is quickly absorbed into the air.

Humidity Source POSITIVE CAPACITY ATOMIZING humidifiers produce moisture that will quickly be absorbed in to the air stream, provided there is no impingement. It is therefore most important that all directions and minimum dimensions be strictly adhered to In order to avoid condensation.

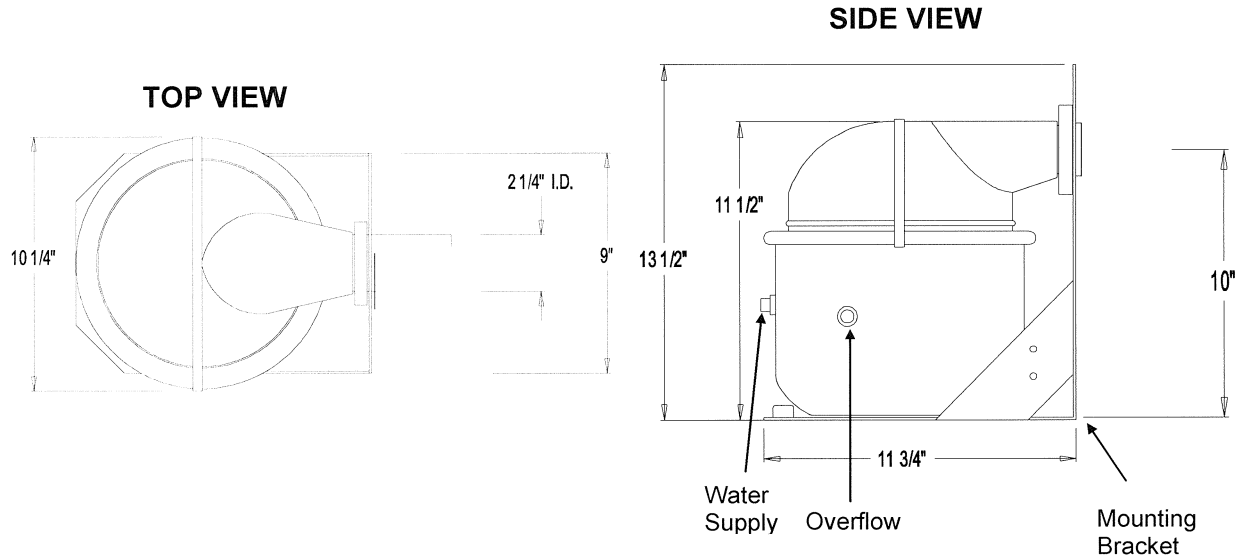

Duct Location Requirements

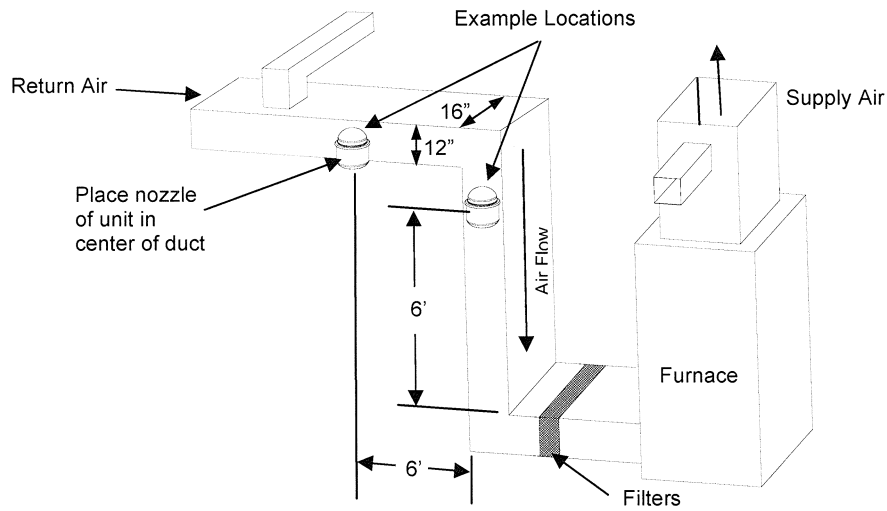

ACCESSORIES

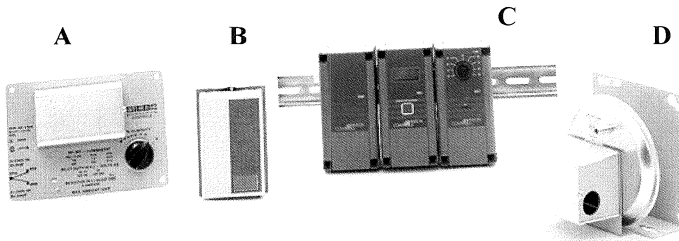

- A. Duct mounted, high limit humidistat. Model No. HC-201
- B. Wall mounted humidistat. Model No. P825.
- C. Johnston Controls electronic humidistat. Model No. W351 with remote sensor (E)
- D. Air duct pressure switch. Model No. PC-301

MODEL WF-225

Your humidifier has been designed and engineered to give, with proper care, many years of trouble free service. Therefore, if this unit ceases to operate properly, we suggest you contact your local dealer. If we, at Humidity Source, can be of any assistance to you, please feel free to write, call or e-mail.

APPLICATION

The WF-225 is designed for forced air systems only mounted on the return air duct. The unit must be wired to function only when the furnace fan is in operation. A typical return air duct installation is shown in Figure C. All dimensions and mounting positions are considered minimum to prevent wetting of internal duct surfaces. The WF-225 output is sufficient for forced air furnaces up to 125,000 BTU output.

INSTALLING

Water Supply. Run a water supply line from an existing cold water pipe using 1/4" o.d. copper or plastic tubing or 1/8" pipe (see Figure A). A saddle valve and compression fittings are a convenient way to run the supply water line to the humidifier. Flush water feed lines before making final connection to avoid foreign objects which may clog the float valve.

Mounting. The WF-225 comes with a duct mounting plate to support the unit. Place the mounting plate at a point where the humidifier is to be installed. Scribe a hole for discharge tube and mounting screw locations. Cut out the hole for vapor discharge tube. Drill (2) 9/32" holes to accommodate top of mounting plate for 1/4"-20 bolts. The rest drill with #30 drill for #10 sheet metal screws. Install mounting plate on duct.

Insert (3) rubber feet in bottom of mounting plate using nuts to secure. Tighten front nuts only.

Set reservoir in place and connect water line. Turn on water valve and adjust water level to 1/2" below the overflow connection by adjusting the thumb screw as shown in Figure D.

Insert atomizer assembly into reservoir with power cord in notch provided in reservoir. Fit tube seal over vapor discharge tube. Set dome over atomizer and through mounting plate and hole in duct. Adjust reservoir to touch front rubber feet then slide the tube seal against the mounting plate. Slide rear rubber foot against the reservoir holding it in place, tighten nut.

WIRING. Provide standard electric receptacle to receive electric cord from humidifier. Power for humidifier must come from the furnace blower motor to insure that it never runs unless there is air flow.

A humidistat may be wired in series with the hot leg from the blower motor. See wiring diagram, Figure B. Plug in the humidifier, it is now ready for operation.

CARE OF THE MACHINE

Periodically the atomizing unit should be removed from the reservoir and given a careful visual check. The pump tube should be spun by hand to make sure that it is free to revolve without binding. See maintenance instructions.

Typical Water Connections

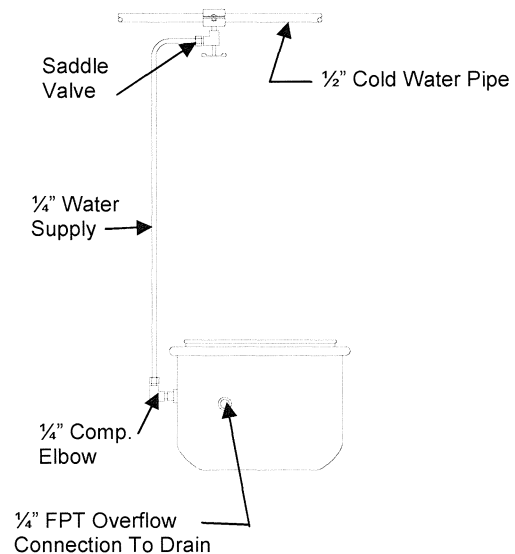

Figure A

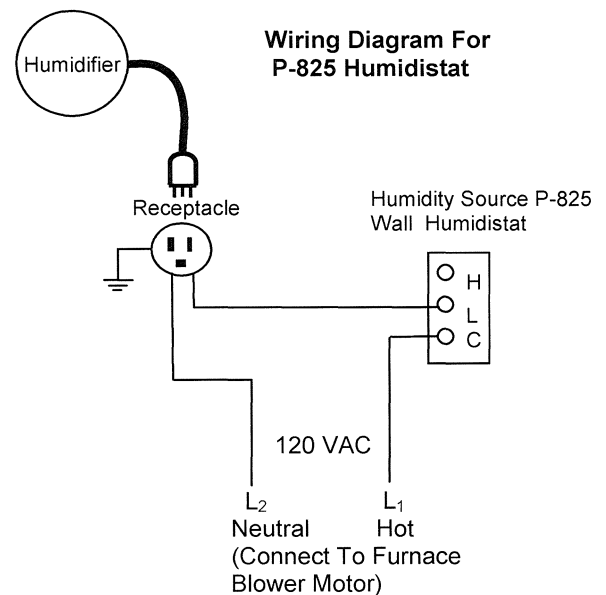

Figure B

W351A Wiring Diagram – On/Off Control

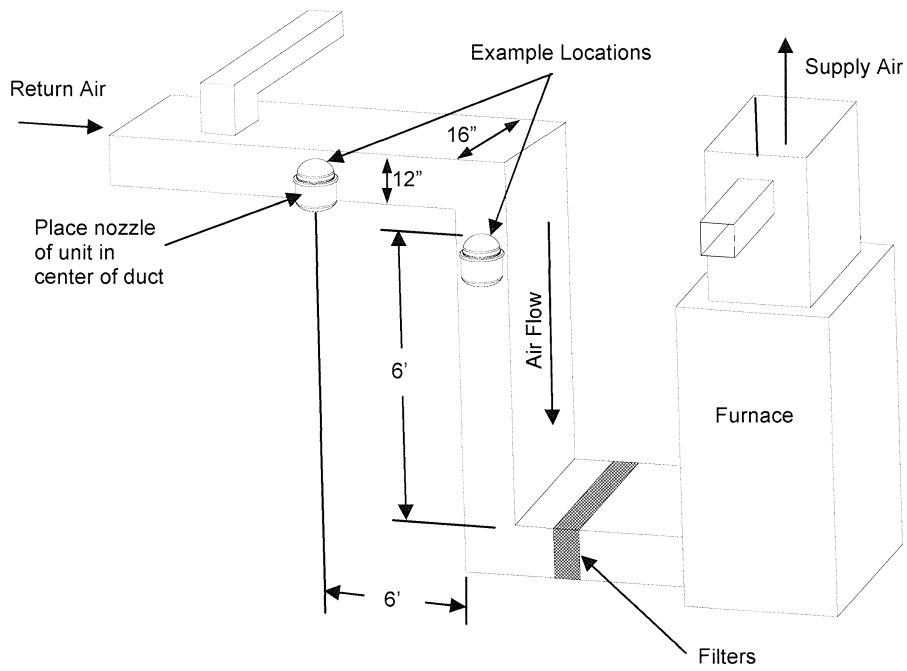
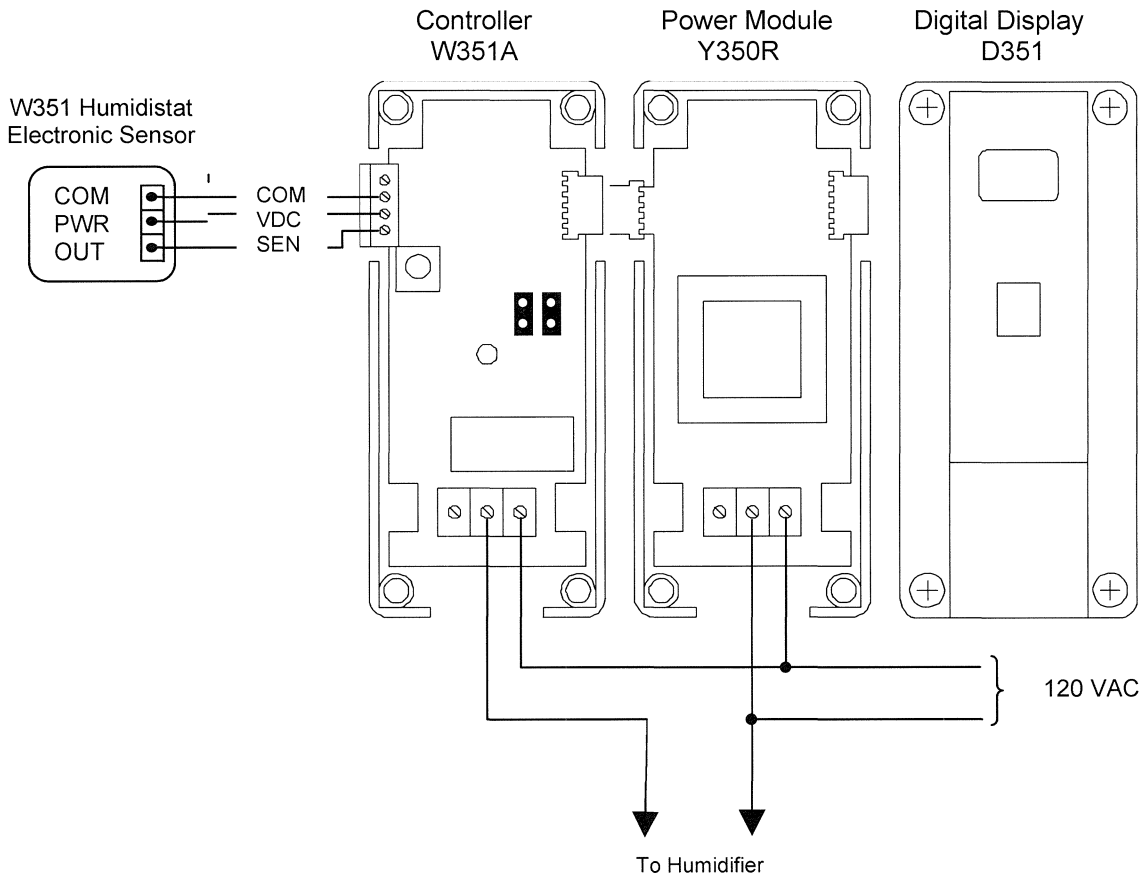

Figure C

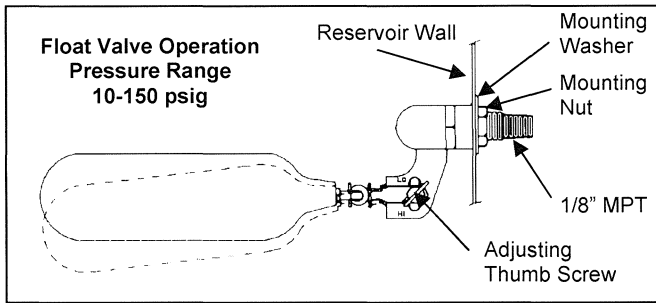

Figure D

OPERATION

Positive capacity atomizing humidifiers produce a mist that will quickly evaporate into the air if there is no impingement of water particles against barrier surfaces before the water is completely absorbed. Strict attention to minimum clearance dimensions must be adhered to in order to avoid condensation.

MAINTENANCE

Unplug electric cord & remove dome. Carefully lift atomizing unit out of reservoir (Figure E). Hold atomizing unit firmly and remove the perforated screen (E-1) by turning it slightly to the left until the four lugs are in line with the slots. To remove the impeller cap (E-2), hold a flat file or the back of a table knife flat against the side of the tube and gently tap the cap which is held in place by a pressed fit. After the cap has been removed, the inside of the tube is visible and it is simple matter to clean it with a piece of cloth on the end of a screwdriver or a small round brush.

There are three ports through which water makes its way from the pump tube to the top of the rotating disc (E-3). These ports should be cleaned out with the aid of a wire. See drawing on this page.

Replace the impeller cap by tapping it evenly back into place, using plastic handle on screwdriver.

Remove water from reservoir & rinse. Fill reservoir with white vinegar or other mild acid solution. Replace dome & atomizer on reservoir & block outlet of dome with plastic wrap & a rubber band. Run atomizer for ½ hour or until minerals are completely dissolved. If necessary, rinse with diluted chlorine bleach solution. Rinse with clean water and return to service. For hard water problems, see "demineralized water" below.

Inspect float valve assemble periodically, & replace when necessary, or every few years. Should this humidifier need service or repair some time in the future, return only atomizing unit direct to the factory.

DEMINERALIZED WATER

If your local water supply has a high mineral content, (call water company & ask for "total dissolved solids" or T.D.S.) This mineral will create tiny particles of airborne "white dust" when the mist evaporates in the air. To eliminate this dust, use an ion exchange or a reverse osmosis demineralizer. See Humidity Source data sheets for Reverse Osmosis demineralizing filters.

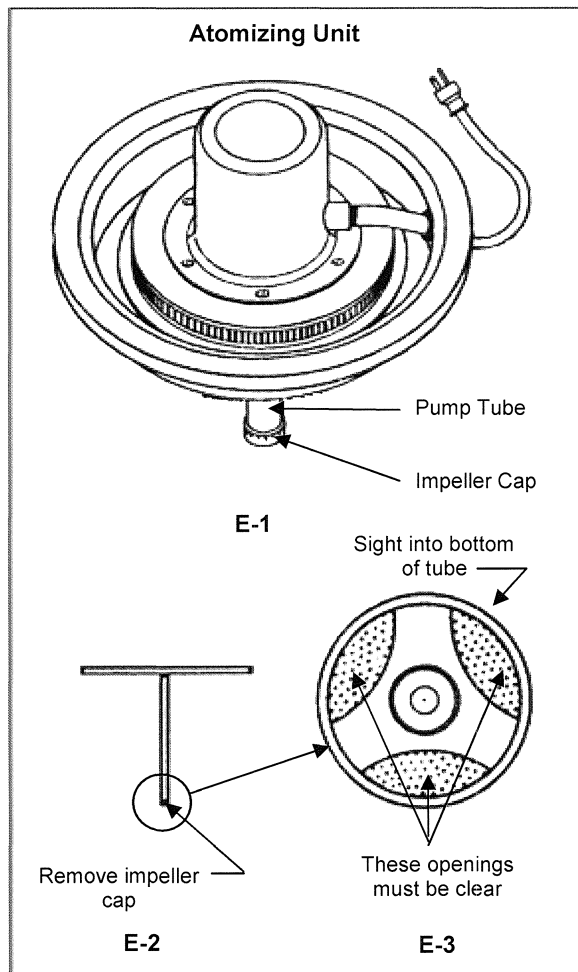

Figure E

MODEL WF-225 REPLACEMENT PARTS

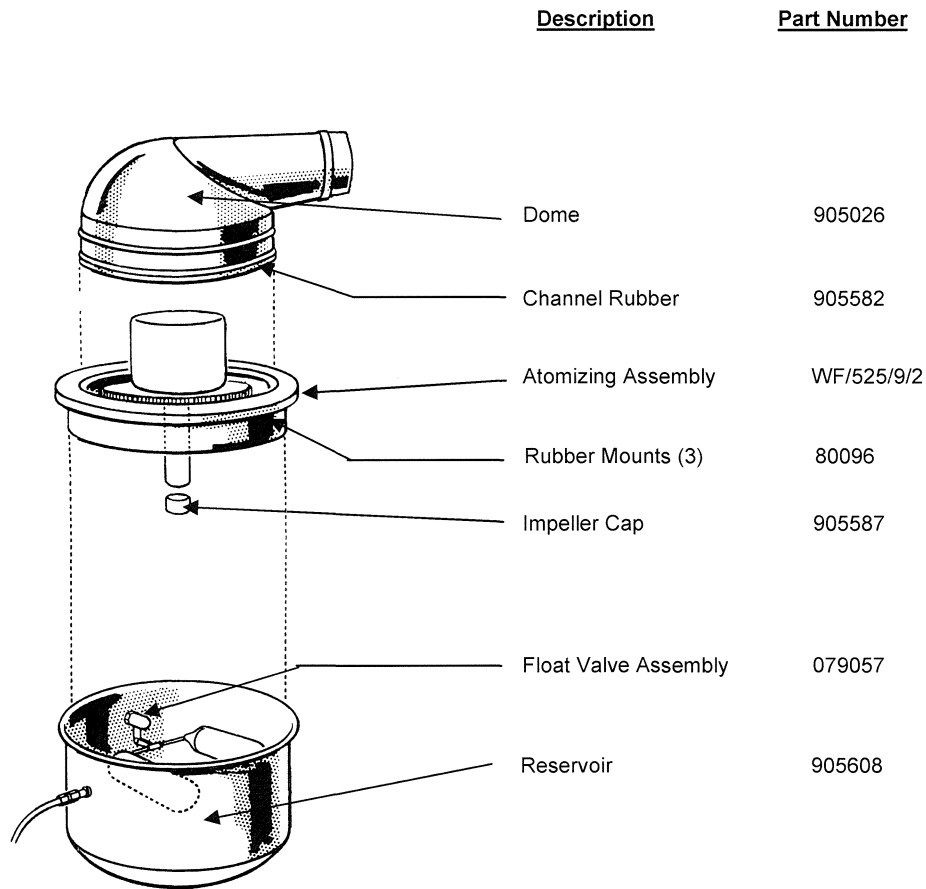
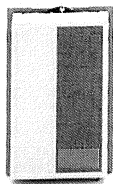

Figure F

Humidifier Accessories

P-825 Humidistat
Human Hair Element



Standard

W351 Humidistat
Electronic Sensor



For high humidity
And/or close
tolerances

Humidity Source Reverse Osmosis water Treatment systems. Sizes range from industrial capacities down to individual room units.

